

General Description

It is mandatory to use Class 1 wireless receiver modules in applications where human life can ultimately depend upon the reliable operation of a wireless data link. Such applications include nurse call and dispersed alarms or wireless fire alarm systems.

The up-graded GR2 receiver module meets these requirements and is available on any frequency.

Fully shielded and measuring just 21 x 48mm, Class1 receivers provide a superior route to enhancing the performance of current and future wireless enabled devices.



Applications

- Nurse call
- Dispersed alarms
- Fire alarms
- Domestic and commercial security

Features

- Miniature SIL package
- Switchable data rate filter offers;
2400 baud with -117dBm sensitivity
9600 baud with -110dBm sensitivity
- Fully shielded
- Single supply 2.7 to 10volt operation

Compatible Transmitter Modules

- GT2 (VHF 10mW transmitter module)
- GT2D (UHF 10mW transmitter module)
- GT2HP (VHF 200mW tx module)
- GT2HP-869.6125 (UHF 300mW tx module)

- Analogue, Digital and true RSSI outputs
- Common genesis footprint
- Operation on any VHF/UHF band
- Other channels available on request
- High blocking immunity in miniature package
- Channel spacing 25 KHz

Absolute Maximum Ratings: Receiver

Operating temperature:	-10°C to +55°C
Storage temperature:	-40°C to +100°C
Supply Voltage (pin 5)	10V
RF Input (pin 1)	10mW

Electrical Characteristics: Receiver (869 MHz versions at 25degC & 2400 baud)

	pin	min.	typ.	max.	units	notes
DC LEVELS						
Supply voltage		2.7		10	V	
Supply current			37	39	mA	
Supply ripple		-	-	10	mV _{P-P}	
Leakage current with Rx in sleep mode				1	uA	
RF						
RF sensitivity			-117		dBm	1
IF Bandwidth			+/-12		KHz	
Initial frequency accuracy			±25		Hz	
Max R.F. input			10		dBm	
Blocking			84		dB	
E.M.C.						
Spurious responses upto 1GHz			<60		dB	
LO leakage, conducted			<70		dBm	
LO leakage, radiated			<70		dBm	
Image rejection			65		dB	
Adjacent channel rejection			70		dB	
DYNAMIC TIMING						
Power up to stable data (With RF signal present)			25	30	mS	
Signal to stable data (With power supply already on)				3.0	mS	
Power up to valid RSSI (with RF signal present)			3.5	4.5	mS	
Mark:space ratio			50		%	
Bit rate		100		9600	bps	

Notes

- 1) For 12dB SINAD measured on AF output with 2400 baud filter selected.

Connection Details

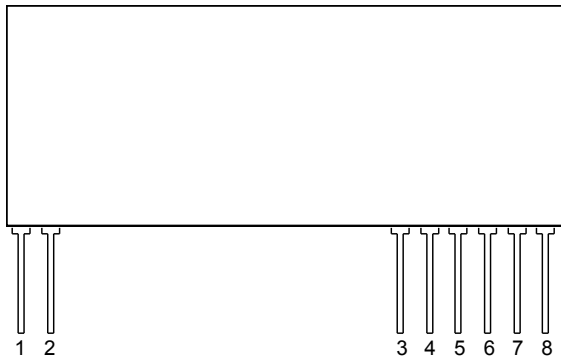

Figure 1: GR2 Receiver

Baud Rate Selection

The module is supplied set to 2400 baud. The 9600 baud data rate can be selected by soldering the 2 sets of solder blob pads on the reverse side of the pcb.

Pin Description

RF IN (*pin 1*)

50 Ω RF input from antenna, connect using shortest possible route. This input is isolated from the internal circuit using the air gap of the front end SAW RF filter.

RF GND (*pin 2*)

RF ground connection, preferably connected to a solid ground plane.

Enable (*pin 3*)

Active high. A low on this pin disables the receiver.

RSSI / Carrier Detect (*pin 4*)

The Received Signal Strength Indicator provides a DC output voltage proportional to the RF input signal. The amplitude of the RSSI voltage increases with increasing RF signal strength. A simple transistor interface can yield a carrier detect logic output.

Gnd (*pin 5*)

Connect to power supply ground

V_{CC} (*pin 6*)

+Ve supply pin. A 100nF decoupling cap as close as possible to this pin and ground is recommended.

AF (*pin 7*)

Audio frequency output 100mV p-p.(max 40uA source)

DATA OUT (*pin 8*)

CMOS compatible output. This may be used to drive external decoders. (Internal 10k pull up)

Mechanical Dimensions

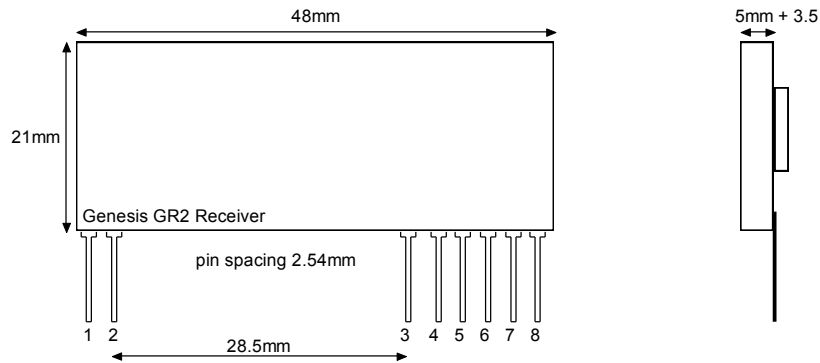

Figure 4: Genesis Receiver

Ordering Information

Part No	Description
GR2-869.2125FMC1	869.2125 MHz receiver module
GR2-869.6125FMC1	869.6125 MHz receiver module
GR2-458.85FMC1	458.85 MHz receiver module
GR2-434.075	434.075 MHz receiver module
GR2-434.275	434.275 MHz receiver module
GR2-434.475	434.475 MHz receiver module

Other frequencies possible

Please consult our sales department for further information.

M.K.Consultants (UK) Ltd

288a – 290 Queens Road
 HALIFAX
 West Yorkshire
 HX1 4NS
 England

Tel +44 (0) 1422 329002

Fax +44 (0) 1422 353153

Email: Sales@mkconsultants.eu

Web: www.mkconsultants.eu

Disclaimer

MKConsultants have a policy to continually improve the reliability and performance of their products. We therefore reserve the right to upgrade our products performance without notice. Although the data contained herewith is believed to be accurate, however we do not assume any responsibility whatsoever for errors or omissions this document may contain. In addition, we do not imply warranty or fitness for any particular application especially life support applications.